

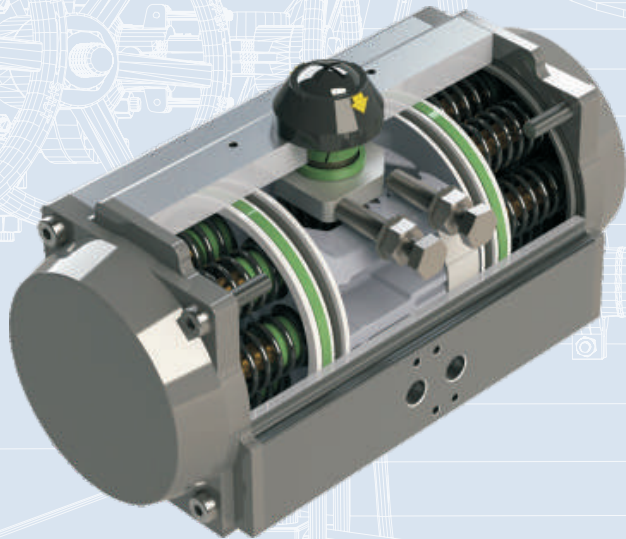

EMFLOW
EST. 2002

PNEUMATIC ROTARY ACTUATORS

CATALOGUE



EM-FLOW ENVIRONMENTAL TECHNOLOGY CO., LTD.

www.emflow.tw



SIL 3 ROHS





◆ Operating Conditions:

1. Operating media:
 - Dry or lubricated air, or the non-corrosive gases
 - The maximum particle diameter must less than 30 um
2. Air supply pressure:
 - The minimum supply pressure is 2 Bar
 - The maximum supply pressure is 8 Bar
3. Operating temperature:
 - Standard: -20°C ~ +80°C (-4°F ~ +176°F) NBR O-ring
 - Low temperature: -40°C ~ +80°C (-40°F ~ +176°F) Silicone O-ring
 - High temperature: -20°C ~ +160°C (-4°F ~ +320°F) Viton O-ring
4. Travel adjustment:
 - Have adjustment range of ± 5° for the rotation at 0° and 90°
5. Application:
 - Either indoor or outdoor

Stroke Adjustment

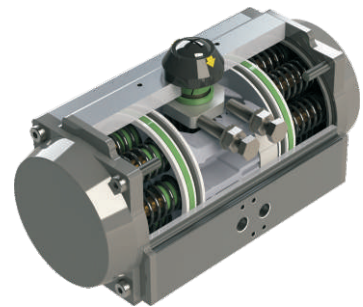
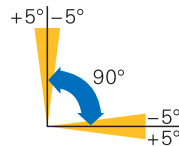

◆ Operating Type:

Double acting and spring return

Principle:



Air supply connection is designed in accordance with NAMUR standard to install solenoid valves.



The Namur drive pinion and the Namur top mounting connection permit direct installation of accessories such as limit switch box and positioner.



Bottom mounting connection is designed in accordance with ISO521 1 and DIN3337 standards for direct mounting with valve gear boxes or mounting brackets.

◆ Working Principle:

Double Acting

Spring Return

Counterclockwise Rotation

Clockwise Rotation

Counterclockwise Rotation

Clockwise Rotation

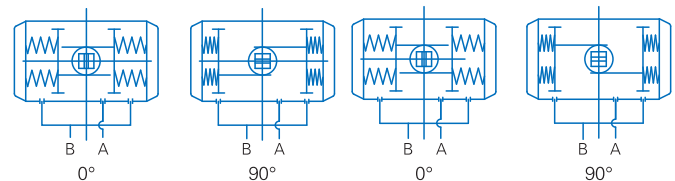
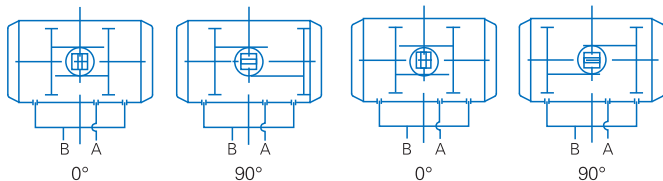

◆ Spring Positions of Spring Return Actuators

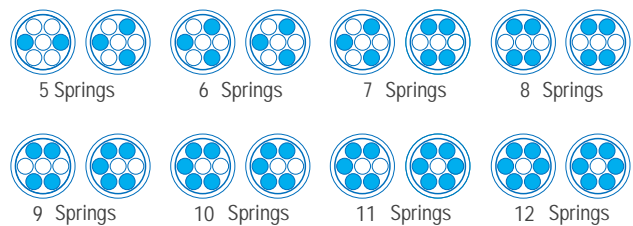

Old Type



New Type



EMP PNEUMATIC ACTUATOR

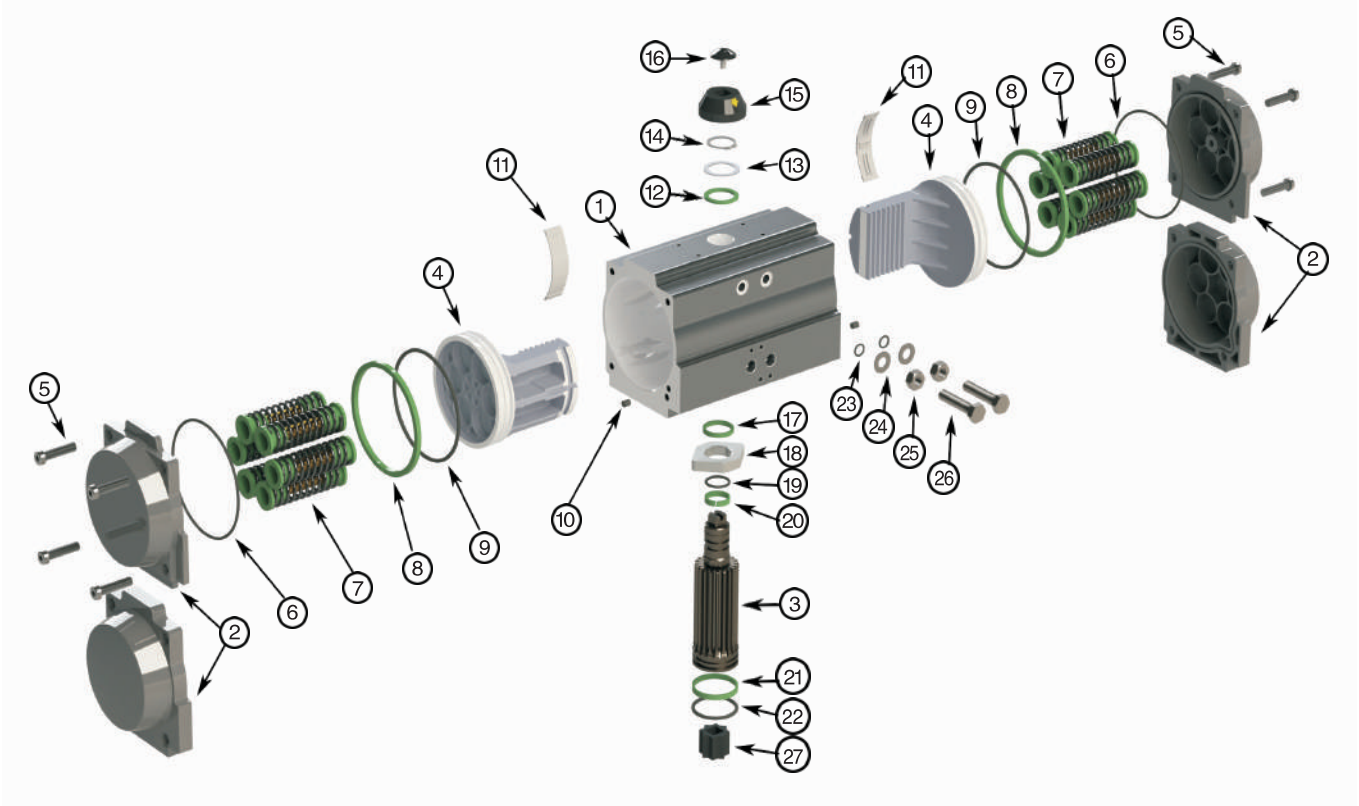

No.	Description	Qty	Standard Material	Protection	Optional Material
1	Body	1	Extruded Aluminum Alloy	Hard Anodized Etc	
2	End Cap	2	Cast Aluminum		
3	Shaft	1	Carbon Steel	Nickel Plated	Stainless Steel
4	Piston	2	Cast Aluminum / Steel	Anodized / Zinc Galvanized	Stainless Steel
5	Cap Screw	8	Stainless Steel		
6	O-ring(End Top)	2	NBR		Viton / Silicone
7	Spring	0-1 2	Spring Steel	Dip Coating	
8	Bearing	2	Engineering Plastics		
9	O-ring(Piston)	2	NBR		Viton / Silicone
10	Plug (Old Type)	2	NBR		Viton / Silicone
11	Guide	2	Engineering Plastics		
12	Outside Washer	1	Engineering Plastics		
13	Thrust Washer	1	Stainless Teel		
14	Spring Clip	1	Stainless Teel		
15	Indicator	1	Plastic		
16	Indicator Screw	1	Plastic		
17	Inside Washer	1	Engineering Plastics		
18	Cam	1	Alloy Steel		
19	O-ring(Shaft)	1	NBR		Viton / Silicone
20	Bearing (Top of Shaft)	1	Engineering Plastics		
21	Bearing (Bottom of Shaft)	1	Engineering Plastics		
22	O-ring (Bottom of Shaft)	1	NBR		Viton / Silicone
23	O-ring(Adjustment Screw)	2	NBR		Viton / Silicone
24	Washer	2	Stainless Steel		
25	Nut	2	Stainless Steel	Powder Polyester Painted etc	
26	Adjustment Screw	2	Stainless Steel		
27	Shaft Adapter	1	Sintered Alloy		

◆ Appearance & Connection Dimension

Connecting Standard ISO51 1/VDI/VDE3845

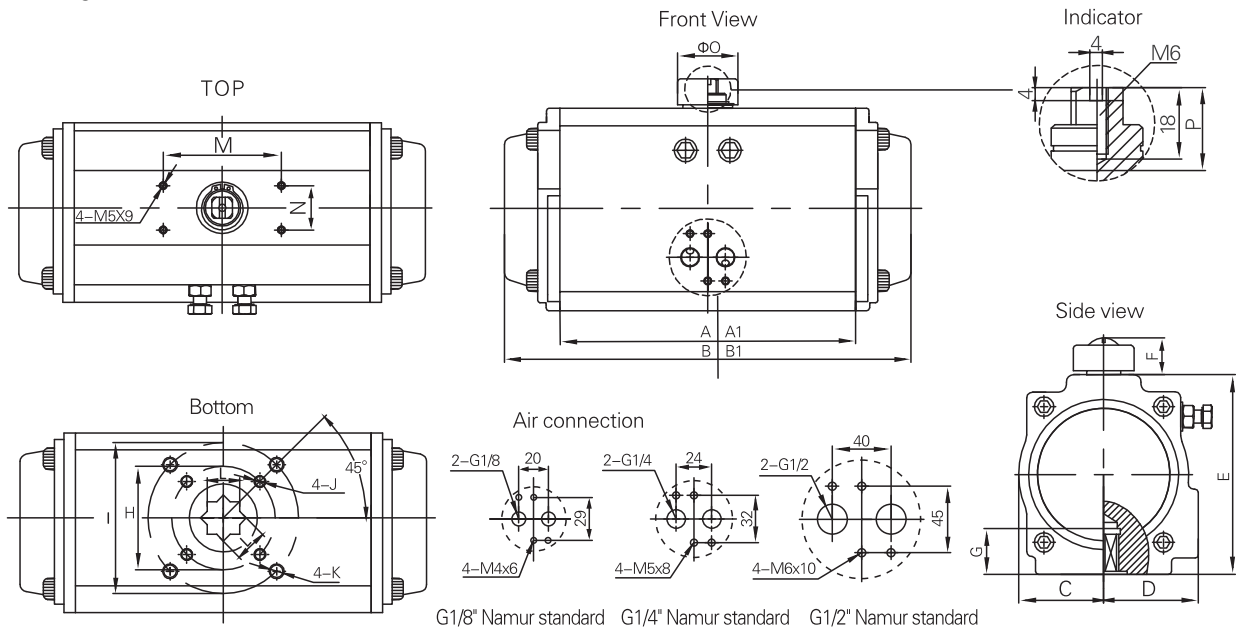

Model	A	A1	B	B1	C	D	E	F	G	H	I	J	K	L	M	N	O>O	P	Air Supply	Weight		
EMP32	DA	90	90	112	112	23.5	23.5	45	26	12	F03	/	4-M5x8	/	9x9	50	30	34	20	G1/8"	0.55	
	SR																				/	
EMP40	DA	93	93	123	123	23.5	33	60	26	12	F03	F05	4-M5x8	4-M6x10	9x9	50	30	34	20	G1/8"	0.66	
	SR																					0.74
EMP52	DA	120	108	145	145	30	41	72	26	15	F03	F05	4-M5x8	4-M6x10	11x11	80	30	34	20	G1/4"	1.2	
	SR																					1.3
EMP63	DA	140	125	169	169	46	46	89	26	15	F05	F07	4-M6x10	4-M8x12	14x14	80	30	34	20	G1/4"	1.9	
	SR																					2.1
EMP75	DA	140	128	201	201	42	52	100	26	15	F05	F07	4-M6x10	4-M8x12	14x14	80	30	34	20	G1/4"	2.8	
	SR																					3.1
EMP83	DA	160	147	209	209	46	55	109	26	15	F05	F07	4-M6x10	4-M8x12	14x14	80	30	34	20	G1/4"	3.2	
	SR														17x17							3.7
EMP92	DA	193	168	242	242	51	57.5	117	26	20	F05	F07	4-M6x10	4-M8x12	17x17	80	30	41	20	G1/4"	4.6	
	SR																					5.2
EMP105	DA	200	186	275	275	58	64	134	26	25	F07	F10	4-M8x12	4-M10x16	22x22	80	30	41	20	G1/4"	6.1	
	SR																					7.1
EMP125	DA	230	207	332	332	67.5	70	157	36	25	F07	F10	4-M8x12	4-M10x16	22x22	80	30	62	30	G1/4"	9.5	
	SR																					10.9
EMP140	DA	290	268	385	400	76	77	174	36	30	F10	F12	4-M10x16	4-M12x20	27x27	130	30	62	30	G1/4"	13.7	
	SR																					15.7
EMP160	DA	340	308	450	455	87.5	87.5	199	38	30	F10	F12	4-M10x16	4-M12x20	27x27	130	30	62	30	G1/4"	20.5	
	SR																					23.6
EMP190	DA	390	390	507	507	103	103	232	38	40	/	F12	/	4-M12x20	36x36	130	30	79	30	G1/4"	31.1	
	SR																					35.3
EMP210	DA	390	390	562	562	113	113	257	38	40	/	F12	/	4-M12x20	36x36	130	30	79	30	G1/4"	41.8	
	SR																					46.6
EMP240	DA	430	430	646	646	129	129	293	38	52	/	F16	/	4-M20x24	46x46	130	30	79	30	G1/4"	62.4	
	SR																					72.4
EMP270	DA	510	510	722	722	146	146	333	38	52	/	F16	/	4-M20x24	46x46	130	30	79	30	G1/4"	86.3	
	SR																					98.3
EMP300	DA	579	579	825	825	162	173	354	38	52	/	F16	/	4-M20x24	46x46	130	30	79	30	G1/2"	103	
	SR																					143
EMP350	DA	580	580	866	866	190	195	410	38	52	/	F16	/	4-M20x24	46x46	130	30	79	30	G1/2"	144	
	SR																					188
EMP400	DA			924	924	258	258	464	38	60	/	F25	/	8-M16x24	55x55	130	30	79	30	G1/2"	289	
	SR																					360

Note: The weights of SR model are included 12 springs.
A and B items for old type, A1 and B1 items for new type.



◆ Double Acting Output Torque In Nm

Model	Input Air Supply Pressure (Unit: Bar)						
	2	3	4	5	6	7	8
EMP32DA	3	5	6	8	9	11	12
EMP40DA	4.8	7.1	9.6	11.9	14.3	16.7	19.1
EMP52DA	8.1	12.1	16.2	20.1	24.2	28.2	32.3
EMP63DA	14.3	21.4	28.5	35.6	42.7	49.8	56.7
EMP75DA	20	30.2	40.3	50.4	60.4	70.5	80.6
EMP83DA	30.9	46.3	61.8	77.1	92.5	108	123.5
EMP92DA	44.2	66.3	88.4	110.5	133	154.8	176.7
EMP105DA	65.8	98.8	131.6	164.5	197.4	230.4	263.2
EMP125DA	102.6	153.9	205.2	256.5	307.8	359.1	410.4
EMP140DA	175.5	263.2	351	438.7	526.3	614.2	702.1
EMP160DA	267.4	401	534.9	668.8	801.8	935.8	1069.7
EMP190DA	450.4	646	861.7	1078.3	1293	1507.7	1723.3
EMP210DA	526.3	789.5	1052.6	1314.8	1578.9	1842.1	2105.2
EMP420DA	773.3	1160	1546.6	1933.3	2319.9	2706.6	3093.2
EMP270DA	1174.2	1761.3	2348.4	2935.5	3522.6	4109.7	4696.8
EMP300DA	1610.8	2416.2	3221.6	4027.1	4832.5	5637.9	6443.3
EMP350DA	2411.8	3617.6	4823.5	6029.4	7235.3	8441.1	9647.1
EMP400DA	3256	4884	6512	8140	9768	11396	13024

◆ Single Acting Output Torque In Nm

Model	Spring Qty	Air Supply Pressure												Output Torque Spring	
		3Bar		4Bar		5Bar		6Bar		7Bar		8Bar		0°	90°
		0°	90°	0°	90°	0°	90°	0°	90°	0°	90°	0°	90°		
EMP52SR	5	8.8	7.3	13.0	11.6									5.4	4.0
	6	8.0	6.3	12.2	10.5	16.5	14.8							6.5	4.7
	7	8.2	5.2	11.5	9.4	15.7	13.7	20.0	17.9					7.6	5.5
	8	6.4	4.1	10.7	8.3	14.9	12.6	19.2	16.8	23.4	21.1			8.6	6.3
	9			9.9	7.3	14.1	11.5	18.4	15.8	22.6	20.0	26.9	24.3	9.7	7.1
	10			9.1	6.2	13.3	10.4	17.6	14.7	21.8	18.9	26.1	23.2	10.8	7.9
	11					12.5	9.4	16.8	13.6	21.0	17.9	25.3	22.1	11.9	8.7
EMP63SR	5	15.7	12.5	23.1	20.0									9.9	6.8
	6	14.3	10.5	21.8	18.0	29.3	25.5							11.9	8.1
	7	13.0	8.5	20.4	16.0	27.9	23.5	35.4	31.0					13.9	9.5
	8	11.6	6.5	19.1	14.0	26.6	21.5	34.0	29.0	41.5	36.5			15.9	10.8
	9			17.7	12.0	25.2	19.5	32.7	27.0	40.2	34.5	47.6	42.0	17.9	12.2
	10			16.4	10.0	23.8	17.5	31.3	25.0	38.8	32.5	46.3	40.0	19.9	13.6
	11					22.5	15.5	30.0	23.0	37.5	30.5	44.9	38.0	21.9	14.9
EMP75SR	5	27.0	21.6	39.3	34.0									15.5	10.2
	6	24.9	18.5	37.3	30.9	49.7	43.3							18.6	12.2
	7	22.9	15.5	35.3	27.8	47.6	40.2	60.0	52.6					21.7	14.2
	8	20.9	12.4	33.2	24.7	45.6	37.1	58.0	49.5	70.4	61.8			24.8	16.2
	9			31.2	21.6	43.6	34.0	56.0	46.4	68.3	58.7	80.7	71.1	27.8	18.3
	10			29.2	18.5	41.6	30.9	53.9	43.3	66.3	55.7	78.7	68.0	30.9	20.3
	11					39.5	27.8	51.9	40.2	64.3	52.6	76.6	64.9	34.0	22.3
EMP83SR	5	33.8	27.2	50.1	43.4									21.5	14.9
	6	30.9	22.9	47.1	39.1	63.3	55.3							25.8	17.8
	7	27.9	18.6	44.1	34.8	60.4	51.0	76.6	67.3					30.1	20.8
	8	24.9	14.3	41.2	30.5	57.4	46.7	73.6	63.0	89.9	79.2			34.4	23.8
	9			38.2	26.2	54.4	42.4	70.7	58.7	86.9	74.9	103.1	91.1	38.7	26.7
	10			35.2	21.9	51.5	38.1	67.7	54.4	83.9	70.6	100.2	86.8	43.0	29.7
	11					48.5	33.8	64.7	50.1	81.0	66.3	97.2	82.5	47.3	32.7
EMP92SR	5	48.0	39.5	71.3	62.8									30.3	21.8
	6	43.7	33.5	66.9	56.7	90.2	80.0							36.3	26.1
	7	39.3	27.4	62.6	50.7	85.8	73.9	109.1	97.2					42.4	30.5
	8	34.9	21.4	58.2	44.6	81.5	67.9	104.7	91.2	128.0	114.4			48.4	34.9
	9			53.8	38.6	77.1	61.8	100.4	85.1	123.6	108.4	146.9	131.6	54.5	39.2
	10			49.5	32.5	72.8	55.8	96.0	79.0	119.3	102.3	142.6	125.6	60.6	43.6
	11					68.4	49.7	91.7	73.0	114.9	96.3	138.2	119.5	66.6	47.9
12					64.0	43.7	87.3	66.9	110.6	90.2	133.8	113.5	72.7	52.3	

◆ Single Acting Output Torque In Nm Continued

Model	Spring Qty	Air Supply Pressure												Output Torque Spring		
		3Bar		4Bar		5Bar		6Bar		7Bar		8Bar		0°	90°	
		0°	90°	0°	90°	0°	90°	0°	90°	0°	90°	0°	90°			
Start	End	Start	End	Start	End	Start	End	Start	End	Start	End	Start	End			
EMP105SR	5	64.6	57.7	99.2	92.4									46.2	39.3	
	6	56.7	48.5	91.4	83.1	126.0	117.8							55.4	47.2	
	7	48.9	39.3	83.5	73.9	118.2	108.5	152.8	143.2					64.6	55.0	
	8	41.0	30.0	75.7	64.7	110.3	99.3	144.9	133.9	179.6	168.6			73.9	62.9	
	9			67.8	55.4	102.4	90.1	137.1	124.7	171.7	159.3	206.3	194.0	83.1	70.7	
	10			59.9	46.2	94.6	80.8	129.2	115.5	163.9	150.1	198.5	184.7	92.3	78.6	
	11					86.7	71.6	121.4	106.2	156.0	140.9	190.6	175.5	101.6	86.5	
	12					78.9	62.4	113.5	97.0	148.1	131.6	182.8	166.3	110.8	94.3	
	EMP125SR	5	131	104	192	166									80	53
		6	120	88	182	150	243	211							96	64
		7	110	72	171	134	232	195	294	257					112	74
		8	99	56	161	118	222	179	283	241	345	302			128	85
9				150	102	211	163	273	225	334	286	395	347	144	96	
10				139	86	201	147	262	209	323	270	385	331	160	106	
11						190	131	251	193	313	254	374	315	175	117	
12						179	115	241	177	302	238	363	299	191	127	
EMP140SR		5	188	144	280	236									133	89
		6	170	117	263	209	355	302							160	107
		7	152	90	245	183	337	275	430	368					187	125
		8	135	64	227	156	319	249	412	341	504	433			213	142
	9			209	129	302	222	394	314	486	407	579	499	240	160	
	10			191	103	284	195	376	288	469	380	561	472	267	178	
	11					266	169	358	261	451	353	543	446	293	196	
	12					248	142	341	234	433	327	525	419	320	214	
	EMP160SR	5	286	222	427	362									201	136
		6	259	182	400	322	541	463							241	163
		7	232	141	373	282	513	423	654	564					281	190
		8	205	101	345	242	486	383	627	524	768	664			321	218
9				318	202	459	343	600	483	741	624	881	765	361	245	
10				291	162	432	303	573	443	713	584	854	725	401	272	
11						405	263	545	403	686	544	827	685	441	299	
12						377	222	518	363	659	504	800	645	481	326	
EMP190SR		5	448	332	675	559									349	232
		6	402	262	629	489	856	716							418	278
		7	356	192	582	419	809	646	1036	873					488	325
		8	309	123	536	350	763	576	990	803	1217	1030			558	371
	9			490	280	717	507	943	733	1170	960	1397	1187	627	418	
	10			443	210	670	437	897	664	1124	891	1351	1117	697	464	
	11					624	367	851	594	1077	821	1304	1048	767	510	
	12					577	297	804	524	1031	751	1258	978	837	557	
	EMP210SR	5	638	468	950	780									467	297
		6	579	375	890	687	1202	998							560	356
		7	519	282	831	593	1143	905	1455	1217					654	416
		8	460	188	772	500	1083	812	1395	1123	1707	1435			747	475
9				712	407	1024	718	1336	1030	1647	1342	1959	1653	840	535	
10				653	313	965	625	1276	937	1588	1248	1900	1560	934	594	
11						905	531	1217	843	1529	1155	1840	1467	1027	653	
12						846	438	1158	750	1469	1062	1781	1373	1121	713	
EMP240SR		5	963	666	1452	1155									799	503
		6	862	506	1351	995	1840	1484							959	603
		7	762	346	1250	835	1739	1324	2228	1812					1119	704
		8	661	187	1150	675	1639	1164	2127	1652	2616	2141			1279	804
	9			1049	515	1538	1004	2027	1492	2515	1981	3004	2470	1439	905	
	10			949	355	1437	844	1926	1333	2415	1821	2903	2310	1599	1005	
	11					1337	684	1825	1173	2315	1661	2803	2150	1759	1106	
	12					1236	524	1725	1013	2213	1501	2702	1990	1919	1207	
	EMP270SR	5	1431	1028	2118	1715									1033	630
		6	1305	821	1992	1508	2679	2195							1240	765
		7	1179	615	1866	1302	2553	1989	3240	2676					1446	882
		8	1053	408	1740	1095	2427	1782	3114	2469	3801	3156			1653	1008
9				1614	889	2301	1576	2988	2263	3675	2950	4363	3637	1860	1134	
10				1488	682	2175	1369	2862	2056	3549	2743	4237	3430	2066	1260	
11						2049	1162	2736	1849	3423	2536	4111	3223	2273	1386	
12						1923	956	2610	1643	3297	2330	3985	3017	2480	1512	
EMP300SR		5													1061	730
		6	1316	875											1273	876
		7	1153	639	1916	1402									1485	1022
		8	991	403	1754	1166	2517	1929							1697	1168
	9			1592	930	2355	1693	3118	2456					1909	1314	
	10			1430	695	2193	1458	2956	2221	3719	2984	4482	3747	2122	1460	
	11					2030	1222	2793	1985	3556	2748	4319	3511	2334	1606	
	12					1868	986	2631	1749	3394	2512	4157	3275	2546	1752	
	EMP350SR	5													1702	1173
		6	1863	1157											2043	1408
		7	1602	779	2745	1922									2383	1642
		8	1341	401	2484	1544	3626	2686							2724	1877
9				2224	1165	3336	2307	4508	3449					3064	2112	
10				1963	787	3105	1929	4247	3071	5390	4214	6532	5356	3405	2346	
11						2844	1551	3986	2693	5129	3836	6271	4978	3745	2581	
12						2584	1172	3726	2314	4869	3457	6011	4599	4086	2816	
EMP400SR		8	2550	1225											3292	2100
		9	2259	768	3887	2396									3703	2362
		10	1967	311	3595	1939	5223	3567							4115	2624
		11			3303	1482	4931	3110	6559	4738					4526	2887
	12			3012	1025	4640	2653	6268	4281	7895	5908	9523	7536	4938	3149	
	13					4348	2195	5976	3823	7603	5450	9231	7078	5349	3412	
	14					4057	1738	5685	3366	7312	4993	8940	6621	5761	3674	
	15					3765	1281	5393	2909	7020	4536	8648	6164	6172	3937	
	16							5101	2452	6728	4079	8356	5707	6584	4199	

◆ Air Consumption

Model		EMP32	EMP40	EMP52	EMP63	EMP75	EMP83	EMP92	EMP105	EMP125	EMP140	EMP160	EMP190	EMP210	EMP240	EMP270	EMP300	EMP350	EMP400
Cylinder Air Volume (L)	Open	0.04	0.08	0.1	0.2	0.3	0.5	0.7	1.2	1.5	2.4	3.1	4.3	5.8	10.0	14.5	23.8	35.1	52.6
	Close	0.05	0.11	0.2	0.3	0.5	0.8	1.1	1.8	2.3	3.8	4.9	6.9	9.5	15.2	21.4	29.7	46.3	36
Opening & Closing Time (Second)(A)	DA Open	0.1	0.1	0.2	0.3	0.3	0.4	0.5	0.7	0.9	1.2	1.5	2.0	2.7	3.5	4.0	8.0	10.0	10.0
	SR Close	0.1	0.1	0.2	0.3	0.4	0.5	0.6	0.8	1.1	1.4	1.7	2.2	3.2	4.0	4.5	10.0	12.0	13.0
	DA Open	0.1	0.1	0.3	0.3	0.4	0.5	0.7	0.9	1.2	1.5	1.8	2.4	3.5	4.1	4.5	7.0	8.0	8.0
	SR Close	0.2	0.2	0.3	0.4	0.5	0.6	0.9	1.1	1.4	1.8	2.1	2.8	4.0	4.6	5.0	8.0	9.0	9.0

◆ Mounting Configurations: Valve Interface & Actuator



Size	ISO5211	Options		
32	F03(9x9)	/		
40	F03/F05(11x11)	11x9	11x7	
52	F05/F07(11x11)	11x9	11x7	
63	F05/F07(14x14)	14x11	14x9	
75	F05/F07(14x14)	14x11	14x9	
83	F05/F07(14x14/17x17)	14x11	14x9/17x14	17x11
92	F05/F07(17x17)	17x14	17x11	
105	F07/F10(22x22)	22x19	22x17	22x14
125	F07/F10(22x22)	22x19	22x17	22x14
140	F10/F12(27x27)	27x22	27x19	22x17
160	F10/F12(27x27)	27x22	27x19	22x17
190	F12(36x36)	36x27	36x22	36x19
210	F12(36x36)	36x27	36x22	36x19
240	F16(46x46)	46x36		
270	F16(46x46)	46x36		
300	F16(46x46)	46x36		
350	F16(46x46)	46x36		
400	F25(55x55)	/		

◆ Top Mount Interface



Namur(VDI/VDE 3845) mounting configuration of all types of top mounted accessories.

Size	Height
32	50x30-H26
40	50x30-H26
52	80x30-H26
63	80x30-H26
75	80x30-H26
83	80x30-H26
92	80x30-H26
105	80x30-H26
125	80x30-H36
140	130x30-H36
160	130x30-H38
190	130x30-H38
210	130x30-H38
240	130x30-H38
270	130x30-H38
300	130x30-H38
350	130x30-H38
400	130x30-H38



EM-FLOW ENVIRONMENTAL TECHNOLOGY CO., LTD.

Add: 29/F, No.68, Section 5, Zhongxiao East Road, Taipei City, Taiwan+886 961

Tel: +886 961-612-974

E-mail: sales@emfow.tw

www.emflow.tw